

COMMENTS FROM THE MAYOR
By Charles Jessup



West Airport Blvd. Reconstruction Project

Well, it is almost time for the shovels to hit the ground on the West Airport Blvd. reconstruction project here in Meadows Place. Probably mid-March. It will be, in technical jargon, “a mess”, but we will do everything we can to make access safe and easy for those of us who live here. Some will be affected more than others. To that end, the City just completed its final set of traffic counts to help us determine which roads to close or make entry or exit only. This will be done to dissuade commuters from detouring through the city and causing problems. Closure maps will be drawn up and put in the newsletter and on the City website. We will also notify you through Code Red and on the Marquee. Final preparations are being made with HDR Engineering and TxDot prior to letting the bid to a construction firm. The project will start just west of Kirkwood, including the intersection and on down to the freeway. The church and all the businesses will be affected and provisions are being made for them as well. We are all cheering this project because it will help the traffic flow through our City and significantly reduce the funds we spend to maintain this area for years to come. This project is part of the Ft. Bend Mobility Bond Project of 2007. Former Council Member Rick Staigle advised we postpone this project twice. Once, so the West Bellfort project could be completed, which would ease the strain of this project on freeway bound traffic and not force it through Meadows Place. The other delay was so he could put together a Traffic Information Plan (TIP) and apply for federal funds, - which resulted in a huge savings for the City. Now the delays are completed, and construction will begin soon. Please contact Public Works Director Dan McGraw at (281) 983-2961 if you have any questions.

(Continued on page 3)



LIFEGUARDS WANTED!

The City of Meadows Place is accepting lifeguard applications until March 28, 2014 for Summer 2014!

You must be 15 years old to apply, and available for **ALL** training dates.

TRAINING DATES

CPR Training: Friday, April 25th
6:00 p.m. - 9:00 p.m.
at the Community Center

Pool Training: Saturday, April 26th
and Sunday, April 27th
9:00 a.m. - 5:00 p.m.
Community Pool

Applications can be picked up and turned in at City of Meadows Place City Hall.

CITY CALENDAR

Feb. 25 Workshop 6:00 p.m.

**Feb. 25 Regular City Council Meeting
City Hall 7:30 p.m.**

Did You Know?...

Did You Know... Meadows Place recently hosted a regional meeting for the Texas Public Works Association? It was held at our community center and due to our great location, was one of their larger turnouts. After their business and board meeting, Meadows Place presented a program on Water Re-use. Public Works Director Dan McGraw then took everyone on a tour of the lake and our Water Reclamation Center at the Waste Water Treatment Plant. I received lots of positive comments and feedback, which made me feel very proud of Meadows Place. Hope you are too.

Did You Know... Meadows Resident Martha Weaver, a long-time professional photographer, recently won an honorable mention award for one of her fine art photos entitled "To Greener Pastures?" The photo of horses taken near Santa Fe, NM was entered in a nationally advertised contest for fine art photos. It can be seen at www.bastropfineartsguild.com/competitions/current-awardees.

Incidentally, Mrs. Weaver is proud to say that her niece Bethany Kamman, of Vail, Colorado, won first place in that contest! Congratulations to both.

Did You Know... in the 2013 State Legislative Session, there was an attempt to pass meaningful legislation to protect citizens from predatory payday and auto title loan companies. Unfortunately, that effort failed but at a recent Texas Municipal League Conference I attended cities were encouraged to pass ordinances of their own to regulate these types of businesses. It has been in the news lately as cities all around us mull over what to do. I want everyone to know that, with the help of our city attorney and his staff, Meadows Place has already passed an ordinance regulating and restricting these types of businesses as they put it, "for the protection of your city." This does not outlaw them, but it does make Meadows Place a less appealing place for them to do business. Thanks Council for your quick actions on our behalf.

Did You Know... Laura Shirley, our Accounts Payable Clerk, called a company who said we owed a \$5.09 late charge for a December bill? Ms. Shirley called them and asked when they received it and said since we processed it on time, maybe it was a mail delay, and they should not charge us. They said we were right and dropped the charge. I know that is not a lot of money, but it shows how carefully our tax money is looked after. Thank you, Laura!!!

Speaking of being late, **Did You Know...** our water operator was late on filing some test reports to Texas Commission on Environmental Quality (TCEQ)? You may have noticed this in a letter which was issued explaining that these test reports failed to get into the state on time. Please know the water is fine, our new water company just missed sending in the reports properly. Public Works Director Dan McGraw has been in discussions with them, and I feel our reporting will be handled in a more timely and professional manner from now on. We have a very strict and stringent water testing program to ensure our water is safe for all of us. In fact, Meadows Place has some of the best, and safest, water around! Speaking of water...

Did You Know... Meadows Place homeowners had two pools installed in just the last couple of months? We also had a record year for sprinkler system permits and installations. This proves once again that Meadows Place is doing well and worth investing in. If you want to see some ways your neighbors have invested in their homes, take the Home & Garden Club "Don't Move, Improve" Home Tour. Some of these improvement ideas are amazing. Not only is the tour fantastic, this type of reinvestment will help keep Meadows Place... **Your Place for Life!**

Did You Know... is just for YOU - and counts on you for input? Please let us know what is going on and drop a note at City Hall for or email: mayor@cityofmeadowsplace.org. Thank You!

Did You Know... Meadows Place uses Ft. Bend Animal Services in lieu of (very expensive) in-house animal control? Their mission is "to eradicate the spread of rabies..., and control wild, potentially dangerous animals...". They are sometimes far away, so they cannot act as a "dogcatcher," but will pick them up if Director Debbie Horricks says, "we (homeowner) "can safely" hold it for them." They also pick up animals trapped in live animal traps. If you do not have a trap, you can either buy one or visit their facilities, put down a deposit, and they will lend you one. For more information go to the Neighbors section of our website, and click Links to visit their website to see all their programs.

(Comments From The Mayor continued from page 1)

Texas Municipal League

I am proud to announce that the City of Meadows Place has been chosen as a host site for the Texas Municipal League (TML) Small Cities Problem Solving Clinic later this month. This is a small, one day conference conducted especially for representatives from small cities. The TML legal team will be on hand and will open up with legislative updates and common legal problems faced by small, General Law cities like Meadows Place. These can range from water and transportation issues to public safety or human resource issues. There is then a series of specific topics to be addressed before they open the floor to the very popular and very effective Small Cities Q&A. The Q&A segment lets cities discuss issues they are facing or could use help with. The information exchange can prove helpful for all participating parties and often leads to creative solutions for the city posing the original problem or situation. It is expected representatives from some 30 to 40 cities will come to the Meadows Place Clinic. What a wonderful opportunity for Meadows Place to shine, but more importantly, it is an opportunity to extend our network of folks familiar with the tasks involved in operating a small city. This can only prove helpful for everyone, including your Mayor and Council Members who attend.

Input to City Hall

Meadows Place recently completed a survey focusing on a community garden and other long term amenities. The response was wonderful, the best yet, and the individual comments most enlightening. Residents provided us some great ideas, and the results are available on our website; however, you do not need to wait for a survey to provide us with your input, ideas, comments or questions. As Mayor, I frequently receive phone calls and e-mails and so do the Department Heads, City Hall and Council. We all feel the more information we have, the better suited we are to represent you so please, if you have a questions, ask them - it will help Meadows Place continue to be **Your Place For Life**.

Taking Care of Business

Our Business Neighbors are a very important part of the City. This column is dedicated to those businesses.

We have a fantastic new restaurant at the other end of the strip center with Radio Shack. To peek at their menu, go to www.fishtalesfryandgrill.com or just pop over for a quick, delicious meal at our new

Fish' Tales Fry & Grill

For such a small city Meadows Place has some really great places to eat. Be sure to use them.

*Our businesses
need, and deserve,
our support*



COP TALK



By Chief Gary Stewart



Neighborhood Watch Program

The Neighborhood Watch Program, hosted by the Meadows Place Police Department, is a crime prevention program that teaches citizens techniques to reduce the risk of being a victim at home or in public, by training the citizens on the importance of recognizing suspicious activities and how to report them. Residents learn how to make their homes more secure and properly identify their property. Neighborhood Watch allows neighbors to get to know each other and their routines, so that any out of place activity can be reported and investigated.

Implementation of a Neighborhood Watch can result in substantial reductions of crimes. Neighborhood Watch works because people want to assume a more active role in making their community safe. Residents within a neighborhood know who belongs there and who doesn't and what activity is suspicious. Citizens will work with, instead of relying on, law enforcement to combat crime in their community.

The Neighborhood Watch Program consists of a series of programs designed to improve the safety of Meadows Place through the participation of its residents. The activities include Neighborhood Watch Meetings and the Community Awareness Programs.

Please join us at the Tactical Training Center (11803 S. Kirkwood Road) on the 3rd Wednesday of each month from 7:00 pm to 8:00 pm and bring a neighbor.

Save the Date!

 **Concert in the Park**

Featuring

**AD REVOLVING
DOORS**

Friday, April 25, 2014

7:00 - 9:30 pm

March Mailbox Madness



By Jerry Parker

March is MAILBOX MONTH here in the City of Meadows Place! This March marks the 6th Anniversary of our City’s annual event.

Mailboxes are typically constructed to last about 10 years, depending on the materials used. The United States Postal Service (USPS) requires homeowners to maintain and replace worn or damaged mailboxes. If it has been a while since you have replaced yours, take an objective look at it.

HOW TO PARTICIPATE: Through the month of March, send us a “before” and “after” photo of your newly rejuvenated or replaced mailbox via email to code-enforcement@cityofmeadowsplace.org. You may also mail it to City Hall, One Troyan Drive or place it in the Utilities Billing Box. Once we receive your photos, **\$10 will be credited to your water utility bill!**

Some mailboxes only need fresh paint or minor maintenance like rust removal, up-righting the post, etc., while others may need to be replaced altogether. Hardware stores like Lowes, Home Depot, and Court’s Hardware sell reasonably priced replacements, and with a modest amount of effort you will have a fresh new look!

USPS Curbside Mailbox Standards:

- The bottom of the mailbox should be located between 41 - 45 inches in height from the surface of the curb.
- The name and address on your mailbox should be at least 1 inch letters/numbers.
- The front of your mailbox door should be located 6 - 8 inches from the front face of the curb.

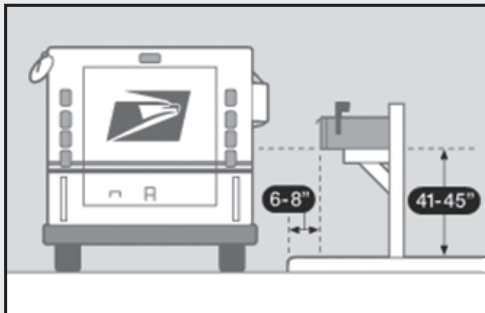

Please contact our local post office if you are considering moving the location of your mailbox.

I would like to thank you in advance, and I am anxious to see just how many of us take advantage and make our beautiful city just a little brighter!

*Code Enforcement Official • Office: 281-983-2938
E-Mail: code-enforcement@cityofmeadowsplace.org*

Lawn Work Time

Summer will be here before you know it!!!



By Dan McGraw

February through March is the best time to fertilize your lawn. Build up the lawn by adding compost/soil, especially if making irrigation repairs. Simple adjustments to your irrigation system can save you both water and money. I see a lot of irrigation systems in the city over watering due to sprinkler head/nozzle issues, systems running daily, as well as during and directly after rain days. Below are some maintenance tips for your lawn & irrigation system.

- To keep a lawn healthy you only need to run the system long enough to drop 1” of water/week. It is best to break this up over a three day period. Every other day works best during the week. So YOU can enjoy your lawn on the weekends.
- Best time to water your lawn - between the hours of 4:am and 8:00 am
- The three best ways to conserve costly water that flows through the highly accurate city water meter is to make sure you have a rain sensor connected to your irrigation system time clock, nozzles are the correct size, correct pattern for your landscape layout and VERY important, water pressure to the system.
- **Rain sensor:** if you do not have a sensor you need to add a sensor. This is a state & city requirement! A sensor controls the operation of the system. If it starts raining while your system is running it will automatically turn itself off and will restore operation after sensor dries. Sensors can be adjusted to stay off for days after rain events. This is the best conservation tool we have in our arsenal and will save you money on your water bill.
- **Nozzles:** if you have an older irrigation system, you may consider upgrading the nozzles to a new low angle rotary nozzle which uses less water.
- **System Pressure:** if your system has a lot of spray like mist (over spray) rising up into the air while your system is running, your system is way over pressure! Easy fix is to add a pressure reducer. Cost \$10

Look for the Public Works article in the upcoming March Newsletter. I will be able to inform you on how to obtain information from our NEW, Smart Water Meter. Below are a couple examples;

- Average daily usage, weekly, monthly and yearly. Using easy to understand graphs!
- Small drip leak notification – now we can inform you when we are notified that you have a consistent small flow through the meter.
- Let’s say your irrigation system starts at 5am and ends at 6 am. Now, I can tell you exactly how many gallons you use each cycle. This type of information allows you to make better decisions when using water at your home. What a great tool !!!



May 10, 2014 Municipal Election Information

City Council Positions Up for Election:

- Mayor Currently Being Held By Charles D. Jessup, IV
- Alderman I Currently Being Held By John F. Isbell
- Alderman II Currently Being Held By Terry W. Morgan
- Alderman III Currently Being Held By David A. Wilkens

Each position is for a two (2) year term. In addition to the Council Workshops and Meetings held on the 4th Tuesday of each month, the City Council also meets for special workshops and meetings throughout the year.

Deadline to File An Application for Place on the Ballot:

- Start Date: Wednesday, January 29, 2014
8:00 a.m. to 5:00 p.m.
- End Date: Friday, February 28, 2014
8:00 a.m. to 5:00 p.m.

Candidate Eligibility General Requirements

A candidate must:

- (1) be a United States Citizen;
- (2) be 18 years of age or older on the first day of the term to be filled at the election;
- (3) have resided continuously in the state for 12 months and in the city or in the district or ward, as applicable, for six months immediately preceding the deadline for filing an application for a place on the ballot (for a write-in-candidate, preceding the date of the election) [Election Code §141.001(s)].
- (4) must be a registered voter and must have resided within the municipal limits for at least the 12 months preceding the election day.

Over the next several months, more information will be included in the monthly newsletter and posted on the City's website. Should you have any questions, please contact City Secretary Jan Moore at (281) 983-2931 or jmoore@cityofmeadowsplace.org.

Posiciones del Consejo Municipal para Elección:

- Alcalde Actualmente retenido por Charles D. Jessup, IV
- Concejal I Actualmente está retenido por John F. Isbell
- Concejal II Actualmente retenidos por Terry W. Morgan
- Concejal III Actualmente retenidos por David A. Wilkens

Cada posición es para un período de (dos) 2 años. Además del Consejo de talleres y reuniones celebradas en la 4th el martes de cada mes, el Concejo Municipal también se reúne para talleres especiales y reuniones durante todo el año.

Fecha límite para presentar una aplicación para el lugar en la boleta electoral:

- Fecha de Inicio: Miércoles, 29 de Enero 2014
8:00 a 17:00
- Fecha de finalización: Viernes, 28 de Febrero 2014
8:00 a 17:00

Requisitos generales de elegibilidad de candidatos

Un candidato debe:

- (1) ser ciudadano de Estados Unidos;
- (2) tener 18 años de edad o más en el primer día del término a llenarse en la elección;
- (3) haber residido continuamente en el estado durante 12 meses y en la ciudad o en el distrito o barrio, según sea el caso, por seis meses inmediatamente anteriores a la fecha límite para la presentar una solicitud para un lugar en la boleta (para escribir-el-candidato, que procede a la fecha de la elección) [código electoral §141.001(s)].
- (4) debe ser un votante registrado y debe haber residido dentro de los límites municipales para al menos los 12 meses anteriores al Día de las Elecciones.

Durante los próximos meses, más información será incluida en el boletín mensual y publicado en la página web de la ciudad. Si tienes alguna pregunta, póngase en contacto con la Secretaria de la Ciudad Jan Moore al (281) 983-2931 o jmoore@cityofmeadowsplace.org.

I need your vote in the Republican Primary March 4th

Elect

Roxie Roll

for **Judge of the 268th District Court**



Who is Roxie Roll? I believe when you get to know me you will agree that I am the right person to move the 268th District Court forward in this new decade.

My Doctorate of Jurisprudence meets the qualifications to apply as a candidate. However, in addition to my JD, I have the experience that voters should demand. **My experience as an attorney in Fort Bend Criminal Courts is the reason I am in this race.** My ethics and character require that I give my clients the best possible representation and if elected, I will continue this total commitment to the voters of Fort Bend County. *Voters will always know my full attention is in the 268th.*

For the past 15 years I have been a practicing trial attorney in this court, as well as the other District and Misdemeanor Courts of Fort Bend County. *I have successfully provided the accused with quality legal representation in over 2200 cases during these years. This experience is important to developing a good Judge that serves justice and fairness.*

As a licensed CPA and 17 years managing accounting problems before and during law school, I will assure you that my education and experience uniquely qualify me to manage this Court.

I have lived in Fort Bend County for the past 41 years and raised my son and daughter in this great county. Both my children and their families now live in Fort Bend just blocks away from the home where they grew up. ***I am not a politician but my politics are lifelong conservative Republican. I want to serve our county in this capacity because I believe our Judicial system is important and we need caretakers of our laws that are willing to defend our rights and apply the law fairly.***

Public service is an honor and we should never allow long term office holders to consider it their right. Even the President of the United States is limited to 2 terms and I believe Judges should limit themselves to two terms. When you vote in this Republican Primary you now have a choice. I am concerned about the operations of this court and if elected it will be my daily duty to bring honor to this court by fairly applying the law in every case. *It is time for a change and I sincerely ask for your vote.*

Just a note to my friends who may not be Republican, you can vote in the republican primary because **this incumbent is only challenged by me in this primary. Make your vote count for change. It is time, vote for Roxie Roll for Judge.**

See my web site to request an application for a **mail in ballot** before **deadline of 2/21/14,** www@roxieroll.com or **email** me at RoxieRollForJudge@roxieroll.com or **call** 281 498 1820 and I will drop an application to you.

EARLY VOTING is Feb 18 through 28 at 14 locations-----AND, VOTING DAY IN PERSON AT YOUR REGULAR VOTING PLACE IS Tuesday, MARCH 4TH

Pol.Ad paid by Roxie Roll, Candidate and Campaign Treasurer

Class or Program Title

If interested in starting a class or program at our Community Center or outdoor facilities in Meadows Place, follow the format below and send to Meadows Place Parks and Recreation Department, One Troyan Drive, Meadows Place, Texas 77477 or email, parks3@cityofmeadowsplace.org.

Must have class and or program information in writing for approval by 1st Friday of the month in order to meet newsletter deadline 2nd Friday of the month.

Description: (Briefly describe your class or activity)

Who: (Age of students to participate)

Where: (The location of where the participants meet every week)

When: (Include dates and times of your program)

Cost: (How much you plan on charging for your session)

Additional Info: (Include any type of specifics that pertain to your class, such as certain attire, supplies needed, etc.)

Instructor: (Your name, as well as the names of any additional helpers/assistants, along with a short biography of you and contact phone number optional)

Tennis Court Access System

MEADOWS PLACE TENNIS COURT ACCESS SYSTEM

Residents may purchase new Tennis Court access cards at City Hall, Monday through Friday, 9 am to 4 pm

- **Only residents of Meadows Place may purchase a card.**
- **A driver's license AND water bill verifying Meadows Place residency must be shown to purchase the access card.**
- **Access cards are \$50 per card, maximum 2 cards per family.**
- **Cards are valid through May; old cards deactivated end of May.**
- **All tennis players must have access card with them on the courts.**
- **A maximum of three (3) guests allowed per card; all guests must be accompanied by a resident.**

TENNIS COURT RULES POSTED AND ON REGISTRATION CARD MUST BE FOLLOWED AT ALL TIMES.

Our Pleasure is to Serve
TruCare
Transportation, LLC



*For Your Medical & Transportation Needs ...
 We Are Just a Phone Call Away*

**NON-EMERGENCY
 WHEEL CHAIR ACCESSIBLE**

**Tel: 713.771.1554
 Fax: 713.771.1559**

TRANSPORT TO:

- ✦ General Medical Appointment
- ✦ Active Living Senior Living Communities
- ✦ Assisted Living Communities
- ✦ Dialysis
- ✦ Nursing Facilities
- ✦ Out-Patient Surgery
- ✦ Patient Discharge
- ✦ Senior Day Care
- ✦ Therapy
- ✦ Rehabilitation

RECREATIONAL AFFAIRS:

- ✦ Special Events
- ✦ Grocery Shopping
- ✦ Church Services
- ✦ Airport Shuttle
- ✦ Hotel Stay
- ✦ Train & Bus Station
- ✦ Funerals
- ✦ Weddings, Etc.

TruCare
Transportation, LLC

Grand Opening Rosie's Hair Salon

(formerly Laura's Hair Salon)

Located at 11735 S. Kirkwood, Suite A
 Stafford, Texas 77477



Lisa Pruett
 713-816-8929



Dora Torres
 281-770-9603



Mai Tran
 281-732-2552

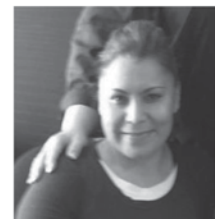

Rosie Gamez
 281-935-7208

We appreciate your business!



City of Meadows Place Parks & Recreation



To participate in any City of Meadows Place program or class, pre-registration is required and most classes have a minimum/maximum enrollment.

PLEASE REGISTER EARLY!

Registration forms can be picked up at City Hall Monday - Friday, 9:00 am - 4:00 pm or printed off the City website www.cityofmeadowsplace.org. Make checks payable to City of Meadows Place; with payment, mail or turn into the City payments box at City Hall. For more information, call Parks & Recreation @ 281.983.2935 or email: parks3@cityofmeadowsplace.org.

Classes

TENNIS ANYONE?!

Description: Beginning Youth Tennis Lessons

Who: Youth 8 - 14 years old

Where: Tennis Courts

When: Wednesdays 6:00 pm / Saturdays 8:00 am

2014 Session 2: February 1 - 26

2014 Session 3: March 1 - 29

Cost: \$75 per session, 4 weeks per session (2 classes per week)
\$40 per session, 4 weeks per session (1 class per week)

Instructor: New Instructor Jami Burt



Turbo Kickboxing Class

Description: Turbo Kick is the revolutionary group exercise program that has changed the direction of kickboxing today. Inspired by dance, Tai Kwon Do, boxing, tai-chi, and funk, this workout creates a party atmosphere!

Who: Ages 13 and up

Where: Community Center, 11975 Dorrance

When: Monday evenings: 7:30 pm - 8:30 pm
Session 2: February 3 - 24

Cost: \$40 per session (4 classes)

Additional Info: Wear shorts & a t-shirt you can move in

Instructor:

Pamela Sampson, Meadows Place resident, has a degree in exercise and sports science, is a Certified Personal Trainer, as well as a Certified Group Exercise Instructor (since 1996) and CPR/AED Trained (current). Please call for more information at 832-577-2403.

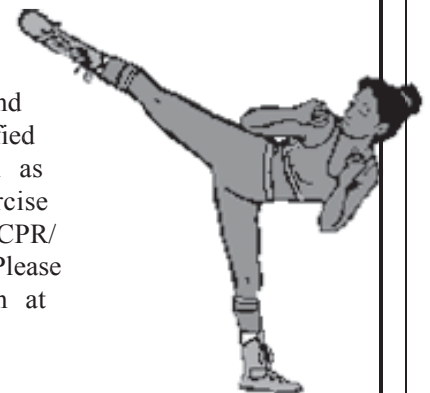

PARKS & RECREATION

PARKS AND RECREATION

Concert

BULLETIN BOARD

Kids Market

- February** Karate & Taekwondo ongoing
It's not too late - sign up now!
- Feb. 1** Tennis Classes Begin!
- Feb. 3** Turbo Kickboxing Begins!
- Feb. - Mar.** Lifeguard Applications Accepted
- April 25** Concert at the Lake
- May 3** Animal Clinic
- May 10** Kids Market

New Sessions Starting Now! Get Registered!

**Contact the Parks Department
about Registration!
281-983-2935**

Kid's Flea Market

**Come join us for the 2nd Annual
Meadows Place Kids' Market!**

What: Kids sell their own handicrafts for **25¢** or **50¢**.
Kids (and adults!) also can buy treasures or goodies
at the market.

When: May 10th, 9:30 am - 11:00 am

Where: McGrath Park, along the trail in the shady area.

Why: To give kids a chance to buy, sell and have a lot of fun!

The Kid's Market is free to participate; everything should be priced at **25¢** or **50¢**! We want a wide variety of merchandise so register your goods and reserve your table by emailing parks3@cityofmeadowsplace.org. The Market is a great place for kids to find the perfect Mother's Day gift!

Taekwondo

Early bird sign up, get a free uniform! (First 10 only)
Come earn a belt!

SHARPEN YOUR MIND, STRENGTHEN YOUR BODY

Sessions Ongoing!

Where: City of Meadows Place Community Center
11975 Dorrance Lane.

Time: Mon. & Wed.: 5:00-6:00pm for children 5-12 years old
Mon. & Wed.: 6:00-7:00pm Adult class (13-up)

2014 Winter Session: Ongoing - March 31
(No class January 20, March 10 & 12)

Fee: 10 Classes - \$49 (1 class per week)
20 Classes - \$90 (2 classes per week)

Instructor: Jenny Pless (City of Meadows Place
resident, teaching at the Community Center
since 2005)



AMERICAN SOCIETY OF KARATE (A.S.K.)

The American Society of Karate is an association designed to teach American Karate to ages 5-70 in a positive ever-changing system. Its goal is not necessarily to be the largest, but to be the best. This class has been on going for 19 years at the Community Center and welcomes new students.

When: Thursdays
Ongoing - March 27 (no class Spring Break week)

Cost: \$45--12 Week Session
\$30--Uniform (sorry no checks, CASH ONLY)

Time: 6:30pm - 7:30pm Junior Class (Ages 5-12)
7:30pm - 8:30pm Adult Classes (Ages 13 and up)

Where: Community Center

Instructors: Steve Puma, Meadows Place resident (3rd Degree Black Belt), Michael Puma (3rd Degree Black Belt)



Classified & Advertising

Anyone wishing to place an ad in the newsletter can contact City Hall for information. All ads are due by the second Friday of each month. The appearance of paid advertising is not an endorsement by the City.

- William Sutherland Handyman Repairs. Appliance, Electrical, Plumbing, Clean out sewer line from 2"-8" pipe. Power washing, interior/exterior, Carpentry work, Painting, Concrete, Tiles. Cell 713-384-2817 / 281-568-0308
- Onyx Landscape. Residential and commercial. Total lawn care. Fertilization, flowerbeds and mulch. Seasonal flowers, sod, tree trimming, tree removal, wood fence installation and repair. Meadows Place resident. Free estimates. Manuel 281-865-6636.
- Pool Cleaning. Full service. Includes cleaning, chemicals, inspecting equipment, emptying baskets. CPO Certified. 281-865-6636 Manuel.
- Sprinklers, new installations, repairs and maintenance. Service all sprinkler systems. Affordable. Licensed/insured. Free estimates. 281-865-6636 #20062
- Mary Kay Cosmetics. Call for re-orders, complementary skin care session, or glamour look. Call Carol: 281-933-8298.
- Daycare enrolling. Meals included. 20 years experience. Melanie 281-495-7996
- Elementary school teacher available for tutoring after school. Texas Certified in Early Childhood through 4th grade with 10 years of elementary teaching experience. Contact Jenina Ramirez, a Meadows Place resident, at (210) 867-7680.

Garage Sale Dates

February
14 & 15

May
9 & 10

August
8 & 9

**Garage
Sale Dates
2014**

November
14 & 15

Home & Garden Club

By Beverly Martin, Publicity

Tuesday, February 11th, the Home and Garden Club will have our International Dinner. There will be no general meeting that evening. Our next general meeting will be on Tuesday, March 11th at the Community Center at 7:00 pm. Please join us for an informative presentation on "Community Gardening." Our guest speaker is Boone Holladay with the Texas A & M Extension Services. Call Lou Ann at 281-568-2989.

The Spring Home and Garden Club Tour will be Saturday, April 26th from 2:00 pm to 5:00 pm. Pre-sale tickets are off to a good start, but we ask you to join us for this Scholarship Award Fund Raiser and purchase tickets. You have a chance to tour several homes and gardens to get great ideas on how to improve your own home. "Don't Move. Improve." Tour Day tickets cost \$15.00. Call now to purchase pre-sale tickets for \$10. Call Kay at 281-933-0729 or Lou Ann at 281-568-2989 or 713-249-8981.

For Meadows Place residents wanting to further their education, visit our website for information about Scholarship Awards given at the end of April. www.meadowshomegardenclub.com

Visit our web site today.

Meadowshomegardenclub.com

Fishing at the Lake!

Catch and release fishing is permitted. Anglers ages 17 and up must have a current fishing license. Discounts are offered to those ages 65+. Grab your pole & bait and head to the lake!

Please do not release any outside fish into the lake or critters into the lake or park.



Free Estimates
Visa, MC, Discover, AMEX

Commercial-Residential
Insured

ODD JOB FENCE COMPANY

Fences Erected, Repaired & Rebuilt

Tim Tate
tate006@gmail.com
281-498-7256

Small, Big, Odd

P.O. Box 1985
Stafford, TX 77477



State lic. & insured
#TACLB 010694E

FRED COMP
Owner

CASUAL AIR & REFRIGERATION INC.

13955 Murphy Road #117
Stafford, Texas 77477

(281) 498-3900
(713) 721-7800



Window City Houston



Replacement Windows

Premium White Vinyl * Double
Pane * Lifetime Warranty *
Professional Installation * Home
of the Ultimate Energy Saver *
Starting at \$189!!!



Winter Specials

\$\$ Huge Savings \$\$
Call Now and Ask About
Our **FREE** Window Offer
Hurry....Sale Ends
February 28, 2014

**FREE
ESTIMATES**

(281) 458-4081

www.WindowCityHouston.com

Meadows Place Residents

WE DESERVE A NICE PARK!

Please Stop or Report
Vandalism or Misuse of Facilities

Police: 281-983-2900

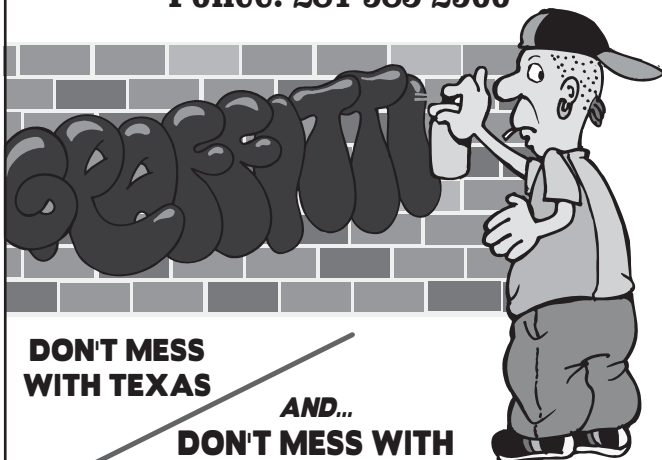

**DON'T MESS
WITH TEXAS**

**AND...
DON'T MESS WITH
Meadows Place**

Stafford Fire Department



is looking for
a few new volunteers from
Meadows Place

Contact info:
Larry Di Camillo
- Fire Chief, City of Stafford Fire Department

ph: 281.208.6950
www.staffordfirerescue.org

10210 Mula Road,
Stafford, Texas 77477



RAY'S

A/C & Heating Services

Tel: 281-799-2556

Maintenance * Service * Installations

Honest & Fair Prices

Manufacturer's
Suggested Annual
Maintenance

Heat check-Up
\$69.00

Anytime

\$150 OFF

Any Replacement
Equipment

Excludes parts

Not valid with any other discount or promotion.
Offers may not be combined. One coupon
per customer.

\$50.00

OFF

Any repair over
\$350

Manufacturer's
Suggested Annual
Maintenance

A/C Check-Up
\$69.00

Anytime



Email: raysmac7@aol.com

www.RaysMac.com



LEAVINGS CONCRETE CO.

- Patios
- Driveways
- Foundations
- Sidewalks
- Lifetime Warranty on Lattice Patio Covers
- Flagstone
- Concrete Pavers
- Stamped Concrete
- Breakout & Removal

713-851-4337

drleavings@peoplepc.com



Don't Make Us Beg!

SELL US YOUR CAR!



TEXASDIRECTAUTO.COM

We make buying and selling fun!



Scan and sell us your car
or search our inventory

ASTRO PLUMBING & TILE

Repair & Remodel Experts

Bellaire • West University • SW Houston



Free Estimates
Senior Discounts

MENTION AD
\$20 OFF

- Drain Cleaning
- Sewer Lines
- Water Lines
- Faucets
- Water Heaters
- Shower Pans
- Yard Drains
- Permits
- Gas Lines & Testing
- Toilets
- Whole House Generators

Reroutes & Tunneling for Kitchen & Bathroom Pipes

Camera Inspection & Leak Detection

Licensed & Insured • Master License 16312



Call Johnny
713-256-0017
23 YEARS EXPERIENCE



www.edwardjones.com

Introducing Ever A. Ramirez

As an Edward Jones financial advisor, Ever is one of the few professionals still making house calls.

Ever is one of more than 12,000 Edward Jones financial advisors serving investors in all 50 states. Edward Jones serves nearly 7 million individual investors nationwide.

Ever wants to put his experience and the extensive resources of Edward Jones to work for you. He'll meet with you at home or at any other convenient location that suits your needs.

Call or visit your local Edward Jones financial advisor today.



Ever A Ramirez
Financial Advisor
5806 New Territory Blvd
Sugar Land, TX 77479
281-565-5353

Edward Jones
MAKING SENSE OF INVESTING

MKT-1956A-A

Member SIPC

THE GALAXIE JEWELERS
WE CREATE THE UNUSUAL
Family Owned Since 1972

2511 SUNSET BOULEVARD "IN THE VILLAGE"
(713) 521-2511 • FAX (713) 521-3700
www.TheGalaxiejewelers.com

Now Enrolling

Kidzz Zone Academy & Daycare

- ▶ STRUCTURE CURRICULUM FOR INFANTS - 12 YRS OLD
- ▶ PRIVATE PRE - KINDERGARTEN, CERTIFIED TEACHERS
- ▶ BEFORE AND AFTER SCHOOL PROGRAM
- ▶ TRANSPORTATION OFFERED TO AND FROM SCHOOL AND HOME
- ▶ NUTRITIOUS MEALS AND SNACKS INCLUDED
- ▶ SAFE & CLEAN ENVIRONMENT

NCI/Worksource Accepted

12336 West Airport Blvd. • Ste D
City of Meadows Place • TX 77477
Tel: 281-776-9800 • Fax: 281-776-9801
Email: kidzzzone@gmail.com
www.kidzzzone.com

Kidzz Zone
Academy & Daycare

OPEN FROM 6:00 AM TO 6:30 PM

No Registration Fee
One week free

Simpson's Tree Service



- Tree Trimming
- Tree Removal
- Senior Citizen Discount!
- FREE Estimates!

\$50 OFF
All services over \$500

\$25 OFF
All services under \$500
with coupon only

Proudly Serving the Greater Houston Area for over 19 Years!

Insured for your protection..
www.SimpsonsTreeService.com
 When Quality Counts...
Call 281.980.0095

Bugs bugging you?
Buzz us!



FREE Home Evaluations & Estimates
 Not valid for WDI reports

\$100 OFF
 Any Complete Termite Treatment
 With coupon.

\$25 OFF
 Ant & Flea Service
 With coupon.

\$59⁰⁰
 Initial Roach Service
 With coupon.

\$89⁰⁰
 House & Yard Spray
 With coupon.

MEADOWS PLACE RESIDENT
 Locally Owned and Operated...

- ✓ 25 Years of Experience
- ✓ Termites & General Pests
- ✓ Free Inspections
- ✓ WDI Inspections/Reports
- ✓ Insured

Direct: 281-610-1053
 or 281-564-1163
MrMikePC@sbcglobal.net



Offer Ends Soon - Call Today

James O. McDonald

Certified Public Accountant
 Serving Our Clients since 1973

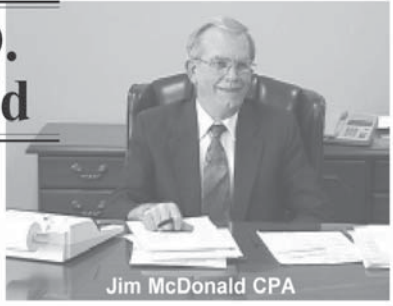

Jim McDonald CPA

Income Tax Planning & Preparation

- Estimating & Planning
- Individual
- Businesses
- Sales Tax
- Property Tax
- Texas Franchise Tax
- Estate Tax

Accounting & Bookkeeping for Small & Medium Size Businesses

- Business and Personal Financial Statements.
- Monthly Bookkeeping.
- Assist in Selection of Accounting Software.
- Financial Analysis and Planning

"We are committed to providing high quality accounting service at reasonable cost. Allow us to provide your accounting services!"

Jim McDonald

7100 Regency Square Blvd • Suite 220
 Houston, TX 77036 • Phone: (713) 771-4628 • Fax: (713) 532-9316

LEVEL PRO HOME SERVICE INC. FOUNDATION REPAIR REMODEL & MORE!

FINANCING AVAILABLE & INSURANCE CLAIMS WELCOME
 WINDOWS • SIDING • FLOORING • KITCHEN & BATH



SHOWROOM
 920 MURPHY RD.#C
 STAFFORD 77477



RANDY ROSE
 281 397-2299 / 888 461-4669
 cell 832 894-0781 fax 281 969-5190

LEVELPROHOMESERVICE.COM



Anita Milne



BEARD REALTY GROUP PRESENTS MEADOWS PLACE HOMES
ON THE MARKET



12243 Meadowhollow



12002 Meadowhollow



11923 Meadowdale



11411 Dorrance



Anita Milne

281-413-9732



11810 Monticeto



milneanita@yahoo.com





One Troyan Drive • Meadows Place, TX 77477

Prsrt Std
U.S. Postage
PAID
Stafford, TX
Permit No. 36

City of Meadows Place

One Troyan Drive • Meadows Place, TX 77477
(281) 983-2950 • Fax (281) 983-2940

- Charles D. Jessup, IV...MAYOR (281) 568-3461
e-mail: mayor@cityofmeadowsplace.org
- Terry J. Henley...MAYOR PRO TEMPORE..... (281) 530-7136
e-mail: alderman4@cityofmeadowsplace.org
- John F. Isbell...ALDERMAN 1 (804) 240-4982
e-mail: alderman1@cityofmeadowsplace.org
- Kelle K. Mills...ALDERMAN 5 (281) 933-0374
e-mail: alderman5@cityofmeadowsplace.org
- Terry W. Morgan, Sr...ALDERMAN 2 (281) 686-4000
e-mail: alderman2@cityofmeadowsplace.org
- David A. Wilkens...ALDERMAN 3..... (281) 782-7861
e-mail: alderman3@cityofmeadowsplace.org
- Janice M. Moore...CITY SECRETARY (281) 983-2931
e-mail: jmoore@cityofmeadowsplace.org

- EMERGENCY 9-1-1
- CITY HALL (9:00 a.m. - 4:00 p.m.) Mon-Fri.....(281) 983-2950
- POLICE DEPARTMENT / 24 Hours.....(281) 983-2900
- FT. BEND COUNTY SHERIFF.....(281) 342-6116
- WATER AND SEWER(281) 398-8211
- FT. BEND COUNTY COURTHOUSE(281) 342-3411
- ANIMAL CONTROL.....(281) 342-1512
- PARKS AND RECREATION DEPARTMENT(281) 983-2935

Community Center Rental

Building Capacity 165

Tables and chairs to accommodate your party.

- Food / no alcohol..... \$150.00
- Food and alcohol..... \$250.00
- Non-residents add..... \$100.00

(Cash Deposit equal to Rental Fee required)

Community Pool Rental..... \$300.00
(Maximum time allowed is 3.5 hours)

Community Center / Pool Combo

Available for rental May - September
Rent both and receive a discount of \$50.00

**CALL PARKS AND RECREATION TO
SCHEDULE YOUR EVENT**

281-983-2935

parks3@cityofmeadowsplace.org

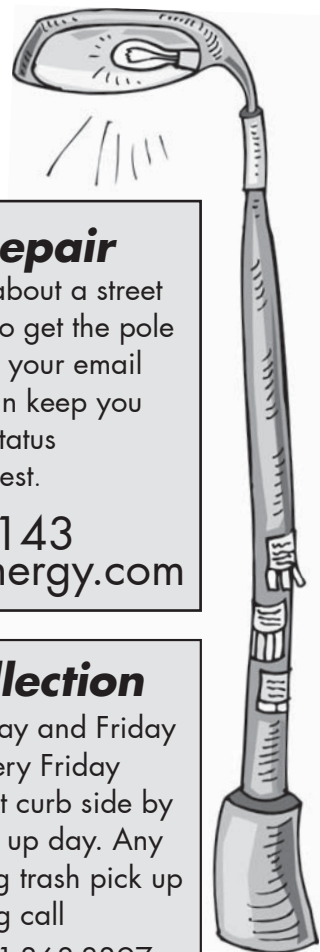

Street Light Repair
When calling or emailing about a street light outage, you will need to get the pole number, and if you add your email address Center Point can keep you apprised of the status of the repair request.
1-800-332-7143
www.centerpointenergy.com

WCA Trash Collection
Trash pick up is every Tuesday and Friday / Recycling every Friday
Please have trash at curb side by 7:00am each pick up day. Any questions concerning trash pick up or recycling call WCA direct at 281-368-8397.

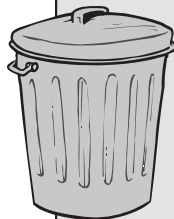

Storm Water Hotline
Report dumping in storm water drains.
Only **RAIN WATER** is allowed
281-983-2932 or report online, see website.
For updates on Public Works News visit the website.
publicworks@cityofmeadowsplace.org