

COMMENTS FROM THE MAYOR
By Charles Jessup



Meadows Place Community Garden

The Meadows Place Community Garden organization met and selected their Board of Directors. They are excited about launching this project. To help move it along, the Board is looking for a Pro bono lawyer to review paper work, volunteers with able hands to build more boxes, students needing service hours, and willing gardeners. We all know that

we need to eat fresh fruits and vegetables for a healthy diet; the Meadows Place community garden program can show everyone how we can grow nutritious foods and is designed to give the community a chance to participate in the process.

If you walk the trail by the parking lot, you will see they have placed the first two raised bed garden boxes and will be planting soon. Meadows Elementary has been invited to participate in the garden and Johanna Garcia “volunteered” her husband to create a website, so expect that soon. In the interim, if you or a group you belong to, are interested in helping or being a part of the Meadows Place Community Garden send an email to: Mpcmgarden@gmail.com. A community garden is ranked as one of the top things a community can do to invest in itself. Thank You to Bob Dybala, Shelly Brough and everyone who has worked so hard to get this fabulous project started. Together, we are creating the culture of our future through planning and participation. It’s almost time to start planting so Bob and Shelly invite everyone to “come grow with us”.

EMS Support for Meadows Place

For the past several months I have been in discussions about the possibility of getting an EMS response vehicle with transportation capability (Ambulance) stationed here in Meadows Place. Multiple conversations with Mayor Scarcella and Chief DiCamillo of Stafford, several members of the Fort Bend County Commissioners Court, Dr. Kendrick, Director of Fort Bend Health and Human Services, Daniel Kosler, Director of Fort Bend EMS and many others have culminated in a formal request to Fort Bend County for an ambulance and crew to be housed here in Meadows Place.

(Continued on page 3)

www.cityofmeadowsplace.org



LIFEGUARDS WANTED!

The City of Meadows Place is accepting lifeguard applications until March 27, 2015 for Summer 2015!

You must be 15 years old to apply, and available for **ALL** training dates. Physical requirements can be found on the website, cityofmeadowsplace.org

TRAINING DATES

CPR Training: Friday, April 17th
6:00 p.m. - 9:00 p.m.
at the Community Center

Pool Training: Saturday, April 18th
and Sunday, April 19th
9:00 a.m. - 5:00 p.m.
Community Pool

Applications can be picked up and turned in at City of Meadows Place City Hall.

CITY CALENDAR

City Meetings

**Feb. 24 City Council Workshop 6:00 p.m.
Regular Meeting 7:30 p.m.**

Fort Bend ISD

Feb. 16 President’s Day/Student Holiday

Did You Know?...

Did You Know... we really need your help picking up the leaves along curbs and gutters, especially around this time of year? The leaves impede water flow, and can fill the storm sewers which can cause the water to backup. We are working on a citywide solution and hope to have it in place next year, but until we do, please help us out by bagging them. Thank You.

Did You Know... The road use fee we collect every month, does not go toward the major reconstruction projects like West Airport and Kirkwood? Those fees are to be used only for repairs on our internal streets, like the ones that run in front of our homes. This will take a little time to build up so we can have a good financial foundation, but we could start using them later this year. These will be used in addition to the funds we budget annually for road repairs and will allow us to address more small street issues every year. If you have any questions on these, or any other fees the city collects, check out the website of call the city or give me a call.

Did You Know... that Sammi Ferriera, who now works for the Skeeters, said Meadows Place not only turned out for the Holiday Lights festival at Skeeters field, but really responded by turning in vouchers benefitting Toys for Tots? She was very proud of her hometown and said Meadows Place was "middle of the pack" in the numbers of vouchers turned in. This is great for a one square mile city. Way to go Meadows Place!

Did You Know... if you want to borrow a Live Trap to capture a critter you can, and then you can have Animal Control come haul it off for you? Jerry Parker, our Code Enforcement Official, says a resident can pick up trap from 1210 Blume Rd. in Rosenberg with \$100 Check deposit. They will give instructions on how to use & bait the trap. Spring is coming and the critters will be active, so call Jerry if you have any questions about this program.

Did You Know... Dan Denny, who works in Parks and Recreation, studied for, took, and passed the Certified Pool Operator (CPO) exam? Being a CPO allows him to expand what he does for us at the pool, which will save us money. Just as important, it makes us even more responsive to the needs of the community. Like Danny, Meadows Place employees are always working to improve themselves allowing them to serve us better. This type of commitment to our community, helps make Meadows Place, *Your Place for Life*.

Did You Know... the mailbox up by the Fire Station and TTC on Kirkwood is temporarily shut down? We put a sign up to let folks know that it should be back up and running by April 15th

Did You Know... one of our neighbors on Meadowdale contacted me about a water leak that had been leaking about a month? He was disappointed in the city's response because he said he had reported it earlier. Somehow the report was never recorded so we didn't know about it until he contacted me with his concern. Turns out it was a small leak on a fire hydrant that needed to be repaired. Of course when he called the second time we responded immediately and got the problem taken care of. Water leaks are important to the city and we make it a priority to get them taken care of, so, if you see a leak, please report it. We would rather have a dozen calls on a leak than none at all. Thank You.

Did You Know... Fred Arnold, with Minute Maid / Coca Cola, chose Tradicao in Meadows Place to hold a very interesting meeting with the Mayors of Sugar Land, Missouri City, Rosenberg and...Meadows Place? Thank You Fred for choosing Meadows Place. We appreciate your patronage.

Do YOU have something for **Did You Know?** Drop a note at City Hall for or email: mayor@cityofmeadowsplace.org. Thank You. Meadows Place... *Your Place for Life!*

Did You Know... Our EDC has been generating a lot of commercial interest in Meadows Place? These projects may or may not come to fruition, but at least we are having serious conversations. This is good news, and we are glad they are, but you can help too. If you know, or want, a business that wants to expand, suggest they move to Meadows Place- that's how Kelley's got here! Fill out the Contact form on the EDC website page or send an email to Bob Graf at... meadowsplacedc@yahoo.com

(Comments From The Mayor continued from page 1)

What caused me to initiate these discussions was a concern over the possibility of increased response times for Meadows Place due to new asset allocations resulting from Sugar Land's new EMS program. This is a big step, and for Meadows Place to get a crew and vehicle stationed here there are several obstacles to overcome, including not having a facility to house the MICU (ambulance), and crew. There is also the problem of a location acceptable to the county, both of which we have made progress on.

I bring this to your attention because I do believe Dr. Kendrick and Commissioners Court will be diligent as they try to deal with our request, but if we are unable to secure an MICU and crew in Meadows Place, we will be partnering with Stafford to explore other options. We are expecting a formal response by the end of February which of course will determine our next course of action. This is an important step for Meadows Place. We will keep you informed. Hopefully this will be one more step in keeping Meadows Place, **Your Place for Life**.

Congressman Olson's "Mobile Office"

I would like to thank Congressman Pete Olson and his staff for holding a "Mobile Office" at Meadows Place. This allowed residents a chance to ask questions in a relaxed one-on-one setting trying to sort out Social Security problems, federal disability filings, Veterans issues, Post Office or IRS problems. This was the first Meadows Place Mobile Office, but it will not be the last. In the meantime, please do not hesitate to contact the Congressman's office at any time.

Taking Care of Business

Our Business Neighbors are a very important part of the City. This column is dedicated to those businesses.

James Coney Island, or JCI, has really expanded its menu. From their Steak & Baby Kale salad, using Nolan Ryan All Natural Beef to their classic Coney Island Dog, JCI is a great place to eat.

James Coney Island

Meadows Place has some really great businesses. Be sure to utilize them. They need, and deserve, our support.



COP TALK



By Chief Gary Stewart



ATM Safety

ATM's have added a real convenience to our lives but, at the same time, an element of risk has also popped up. Using an ATM safely requires awareness and a little planning. Just because an ATM is open for business and available 24 hours a day doesn't mean it is always safe to use. A little common sense can keep most of us out of trouble, but you should periodically review the safety of the ATM you are going to use.

Before using an ATM:

Pick a Safe Location. ATM's are used 24 hours a day. They are susceptible to misuse, vandalism, robbery, and can jeopardize safety of customers. Therefore, use only an ATM in high visibility, high traffic areas with a defined parking area, adequate lighting, and proper landscaping. Do not use ATMs that are remote or hidden behind buildings, behind pillars, walls, or away from public view. Beware of overgrown shrubbery or trees. They make good hiding places and robbers like to have the element of surprise and no witnesses.

Using the ATM:

Try to Limit Your Use to Daylight Hours. Take someone with you, if you can. Use ATM's You're Familiar With. Be Observant. When you drive up to an ATM location, look around. If you see anyone suspicious standing around or just sitting in a car, drive away. **Look Over the Machine Before Inserting Your Card.** If you see something unfamiliar on the machine, it could be part of an ATM scam. If it looks funny, go to another ATM. **Have Your Card in Your Hand.** Be ready to use it right away. You don't want to stand around and take extra time looking for your card in your purse or wallet. **Keep Your Car Secured.** Lock your car if you have to get out to use the ATM machine.

Memorize your personal PIN number to prevent loss and to expedite the transaction. Shield your transaction. Use your body or hand to shield the ATM keyboard when you enter your PIN. Don't give someone else the opportunity to see the number you are entering. Put your cash away immediately in your pocket, wallet or purse, extract your card and walk away. Do not display your cash or count it at the ATM. Cash can be tempting when it is out in the open. Don't leave your receipt. Be sure to take your receipt or transaction records with you when you leave. Never accept an offer of help or request help from a suspicious person at the ATM machine. Robberies are somewhat more likely to occur at walk-up ATM's than at drive-thru ATM's.

The Meadows Place Police Department is concerned about the safety of the community and offers these tips to promote the safety and wellbeing of the community. For further information please contact the Police Department 281 983-2900.



By Jerry Parker

Mailbox Month

March is MAILBOX MONTH here in the City of Meadows Place! This March is the 6th anniversary of this event for our City. Mailbox Month is the time we take a look at what is often the first impression of your home, your mailbox. If it needs to be repaired or replaced, and you do it, this can result in a **\$10 discount** on your water bill!

Mailboxes are typically constructed to last about 10 years, depending on the materials used, and the USPS states that it is the homeowner's responsibility to maintain and replace worn or damaged mailboxes. If it has been quite a while since you have replaced yours, take an objective look at it. It is an easy way to add value.

HOW TO PARTICIPATE: Through the month of March; mail, place in the Utilities Billing Box or e-mail (code-enforcement@cityofmeadowsplace.org) a "before" and "after" photo of your newly rejuvenated or replaced mailbox to City Hall. **Each participating residence will receive a \$10 discount off of their utility bill!**

Some mailboxes only need fresh paint or minor maintenance like rust removal, up-righting the post, etc., while others may need to be replaced altogether. Hardware stores like Lowes, Home Depot, and Court's Hardware sell reasonably priced replacements, and with a modest amount of effort you will have a fresh new look!

CURBSIDE MAILBOX STANDARDS:

- The bottom of the mailbox should be located between 41 - 45 inches in height from the surface of the curb.
- The name and address on your mailbox should be at least 1 inch letters/numbers.
- The front of your mailbox door should be located 6 - 8 inches from the front face of the curb.

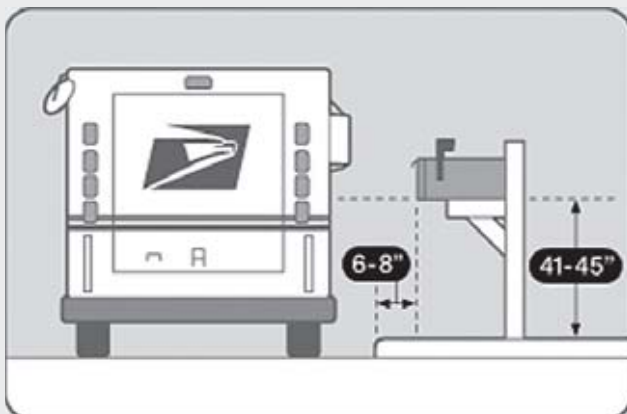

Please contact our local post office if you are considering moving the location of your mailbox.

I would like to thank you in advance, and I am anxious to see just how many of us take advantage and make our beautiful city just a little brighter!

Top Hits from January:

Violation:	Warn/Cit	Comply:
Grass/weeds	0	0
Trees/Shrubs	3	3
Trailer/Car/Boat	4	4
Trash Cans/Debris	35/1	34
General Nuisance	10	8
Totals	52	49

Please note: If you have a Code Complaint, please go to the City Website, (www.cityofmeadowsplace.org) and fill in the complaint form. 1 violation per complaint please.

Code Enforcement Official • Office: 281-983-2938 •
E-Mail: code-enforcement@cityofmeadowsplace.org

Free Estimates
Visa, MC, Discover, AMEX

Commercial-Residential
Insured

ODD JOB FENCE COMPANY

Fences Erected, Repaired & Rebuilt

Tim Tate
tate006@gmail.com
281-498-7256

Small, Big, Odd

P.O. Box 1985
Stafford, TX 77477



May 9, 2015 Municipal Election

City Council Positions Up for Election:

- Alderman IV Currently Being Held By
Terry J. Henley
- Alderman V Currently Being Held By
Kelle K. Mills

Each position is for a two (2) year term. In addition to the Council Workshops and Meetings held on the 4th Tuesday of each month, the City Council also meets for special workshops and meetings throughout the year.

Deadline to File An Application for Place on the Ballot:

End Date: Friday, February 27, 2015
8:00 a.m. to 5:00 p.m.

Candidate Eligibility General Requirements

A candidate must:

- (1) be a United States Citizen;
- (2) be 18 years of age or older on the first day of the term to be filled at the election;
- (3) have resided continuously in the state for 12 months and in the city or in the district or ward, as applicable, for six months immediately preceding the deadline for filing an application for a place on the ballot (for a write-in-candidate, preceding the date of the election) [Election Code §141.001(s)].
- (4) must be a registered voter and must have resided within the municipal limits for at least the 12 months preceding the election day.

Over the next several months, more information will be included in this newsletter and posted on the City's website. Should you have any questions, please contact City Secretary Jan Moore at (281) 983-2931 or jmoore@cityofmeadowsplace.org.



Friendly Reminder

Please make sure your current contact information is updated in our water utilities system.

Email information updates to:
utilities@cityofmeadowsplace.org



Also, when paying your utility bill please make sure your check includes the following to allow us to provide you with superior service:

- Name, Address and current Phone Number
- Payment made out to "City of Meadows Place"
- **Current Date: We cannot accept postdated checks. Postdated payments will be returned**
- Written Payment Agrees with the Numerical Box
- Utility Stub
- Account Number
- Signature

Remembering these helpful tips will allow for timely, efficient, and accurate processing and allow us to serve YOU better! Thank you in advance for your cooperation and for questions contact us at:

(281) 983-2950 or
utilities@cityofmeadowsplace.org

GARAGE SALE
Garage Sale Dates for 2015:
February 13th & 14th
May 8th & 9th
August 14th & 15th
November 13th & 14th



Classified & Advertising

Anyone wishing to place an ad in the newsletter can contact City Hall for information. All ads are due by the second Friday of each month. The appearance of paid advertising is not an endorsement by the City.

- William Sutherland Handyman Repairs. Appliance, Electrical, Plumbing, Clean out sewer line from 2"-8" pipe. Power washing, interior/exterior, Carpentry work, Painting, Concrete, Tiles. Cell 713-384-2817 / 281-568-0308
- Onyx Landscape. Residential and commercial. Total lawn care. Fertilization, flowerbeds and mulch. Seasonal flowers, sod, tree trimming, tree removal, wood fence installation and repair. Meadows Place resident. Free estimates. Manuel 281-865-6636.
- Pool Cleaning. Full service. Includes cleaning, chemicals, inspecting equipment, emptying baskets. CPO Certified. 281-865-6636 Manuel.
- Sprinklers, new installations, repairs and maintenance. Service all sprinkler systems. Affordable. Licensed/insured. Free estimates. 281-865-6636 #20062



"Proudly Servicing Homes in Your Area for 28 Years!"

CASUAL AIR, INC.

"Fair Prices, Quality Work"

• Please have your furnace checked for proper operation by a licensed H.V.A.C. professional before turning them on! **A very small price to pay for you and your loved ones safety.

PREVENTIVE MAINTENANCE TIP ~ FYI:

Have the duct work checked in your homes attic space for air leaks. If your home is 25-30 years old the typical "flex duct" originally installed by builders can deteriorate & literally "fall apart" due to constant heat & humidity of attic conditions in our area. This can hit you hard in the "pocketbook" (i.e. very comfortable attic space!!). Not to mention your system has to work harder to comfortably heat & cool your home. Having your duct work checked can be easily scheduled during your annual fall furnace inspection. **Call Now** before you make the switch to heat.

281.498.3900
Stafford, TX 77477

FRED COMP, Owner

State Lic. & Insured
#TACLB 010694E

G&D Home Repair

Remodeling Interior & Exterior

Our services

Carpentry, Siding, Fences, Hardwood plank, Roofing, Ceramic Tile, Vinyl, Hardw.

Plumbing, Gutters, Pressure Washer, Painting Interior/Exterior

We install

Windows & Doors, Mail Boxes, Counter Tops

Doors Bell, Ceiling Fans, Lights, Fixtures, Stoves

Water Heaters, Filters, Ice makers, Mini Blinds, Etc.

Over 18 years of Experience

Free Estimates

We Accept

Please visit My Web and See Our Video Testimonials

References, Pictures of our Projects and more

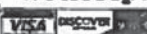

www.gdhome repair.com 713-269-9411



Home & Garden Club

By Rose Melancon, Publicity

We are proud to announce the Christmas Yard of the Month winners.

Section I

Aileen and Tom Clarke
1141 Dorrance

Section IVS

Ian Cusi
12310 Brighton Ln.

Section II

Clyde and Zella Little
11931 Dorrance

Section IVN

Casey Collins Family
11715 Kenzie Ct.

Section III

Paul Russell Griffin
12022 Meadowdale

Section V

Mehboob and Saira Mithani
12502 Meadowglen

Did you miss seeing these award winning Christmas yards? No worries! Check out our web site, meadowshomegardenclub.com for photos of these festive lawns.

While you are there, don't forget to have your Meadows Place college bound student apply for our scholarship award. The deadline for entry this year is April 30, 2015. See "Scholarships" for more information.

The Spring Home & Garden Club Tour, whose proceeds benefit the scholarship award, is coming soon on April 25th. Are you proud of your recently remodeled home or landscaped yard? Consider being part of the Home Tour! Contact Meadows Home & Garden Club President, Bob Dybala, at 713-213-6166 or meadowshomegardenclub@gmail.com.

Just a reminder, the Tour is open only to Meadows Place residents.

Got a question? We'll give you the answer.

Visit our Gmail:

meadowshomegardenclub@gmail.com

Visit our web site today.

Meadowshomegardenclub.com

PARKS & RECREATION



City of Meadows Place

Parks & Recreation



To participate in any City of Meadows Place program or class, pre-registration is required, and most classes have a minimum/maximum enrollment.

PLEASE REGISTER EARLY!

Registration forms can be picked up at City Hall Monday - Friday, 9:00 am - 4:00 pm or printed off the City website www.cityofmeadowsplace.org. Make checks payable to City of Meadows Place; with payment, mail or turn into the City payments box at City Hall. For more information, call Parks & Recreation @ 281.983.2935 or email: parks3@cityofmeadowsplace.org.

Classes



Want to Start a Class or Program?

If interested in starting a class or program at our Community Center or outdoor facilities in Meadows Place, follow the format below and send to Meadows Place Parks and Recreation Department, One Troyan Drive, Meadows Place, Texas 77477 or email, parks3@cityofmeadowsplace.org.

Must have class and or program information in writing for approval by 1st Friday of the month in order to meet newsletter deadline 2nd Friday of the month.

Description: (Briefly describe your class or activity)

Who: (Age of students to participate)

Where: (The location of where the participants meet every week)

When: (Include dates and times of your program)

Cost: (How much you plan on charging for your session)

Additional Info: (Include any type of specifics that pertain to your class, such as certain attire, supplies needed, etc.)

Instructor: (Your name, as well as the names of any additional helpers/assistants, along with a short biography of you and contact phone number optional)



Tennis Court Access System

Residents may purchase new Tennis Court access cards at City Hall, Monday through Friday, 9 am to 4 pm.

- Only residents of Meadows Place may purchase a card.
- A driver's license and/or water bill verifying Meadows Place residency must be shown to purchase the access card.
- Access cards are \$50 per card, maximum 2 cards per family.
- Cards are valid through May; old cards will be deactivated at the end of May.
- All tennis players must have access card with them while on the courts.
- A maximum of three (3) guests allowed per card and all guests must be accompanied by a resident.
- Do not prop open the gate at any time or allow access to the courts to anyone without a Tennis Court access card.

Failure to comply with all rules posted at the Tennis Courts and on the Registration Card may result in forfeiture of Access Cards.

PARKS & RECREATION

PARKS AND RECREATION

Karate

BULLETIN BOARD

Animal Clinic

- February** Karate & Taekwondo ongoing
It's not too late, sign up now!
- Feb. - Mar.** Lifeguard Applications Accepted
- April 24** Music Memories Concert
- May 2** Animal Clinic

Registration forms can be found at
cityofmeadowsplace.org
or at City Hall.

Save the Date!

Music Memoires Concert in the Park

Featuring

AD REVOLVING DOORS

Friday, April 24, 2015
7:00 - 9:30 pm

 *Kid's Market*

3rd Annual Meadows Place Kid's Market

The Kid's Market is free to participate and is designed to teach kids about the free market system while having some fun. Kids should make their own handicrafts, treasures and goodies and price them to sell at the Market. It's time now to start making your handicrafts; the date of the sale will be announced in the next Newsletter.

When: To Be Determined

Time: 9:30 am - 11:00 am

Where: McGrath Park, along the trail in the shady area.

AMERICAN SOCIETY OF KARATE (A.S.K.)

The American Society of Karate is an association designed to teach American Karate to ages 5-70 in a positive ever-changing system. Its goal is not necessarily to be the largest, but to be the best. This class has been on going for over 20 years at the Community Center and welcomes new students.

Where: Community Center

When: Thursdays - Winter 2015 Session
January 15 - March 26 (no class March 12)

Time: 6:30 pm - 7:30 pm (Ages 5-12)
7:30 pm - 8:30 pm (Ages 13-70)

Fee: \$50 (10 Weeks)
\$30 Uniform (cash only, no checks)

Instructors: Steve Puma, Meadows Place resident (3rd degree black belt) & Michael Puma (3rd degree black belt). Since 1993.

 *Taekwondo*

SHARPEN YOUR MIND, STRENGTHEN YOUR BODY

Winter 2015 Session

Where: Community Center

When: Mondays and Wednesdays
January 12 - March 30, 2015
(No class Jan 19, March 9 & 11)

Time: 5 - 6 pm (Children 5 - 12 years old)
6 - 7 pm (Children 13 & up and Adults)

Fee: 10 Classes - \$49 (1 class per week)
20 Classes - \$89 (2 classes per week)
*Free uniform for the first 10 students
who sign up for 20 classes!*

Instructors: Master Jenny Pless
(teaching at the Community Center since 2005)

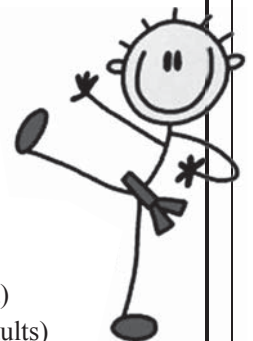

 *Fishing at the Lake!*

Catch and release fishing is permitted. Anglers ages 17 and up must have a current fishing license. Discounts are offered to those ages 65+. Grab your pole & bait and head to the lake!

Please do not release any outside fish into the lake or critters into the lake or park.



LEAVINGS CONCRETE CO.

- Patios
- Driveways
- Foundations
- Sidewalks
- Lifetime Warranty on Lattice Patio Covers
- Flagstone
- Concrete Pavers
- Stamped Concrete
- Breakout & Removal

713-851-4337

drleavings@peoplepc.com

Meadows Place Residents

**WE DESERVE
A NICE PARK!**

**Please Stop or Report
Vandalism or Misuse of Facilities**

Police: 281-983-2900



**DON'T MESS
WITH TEXAS**

**AND...
DON'T MESS WITH
Meadows Place**

**Stafford Fire
Department**



**is looking for
a few new volunteers from
Meadows Place**

Contact info:
Larry Di Camillo
- Fire Chief, City of Stafford Fire Department

ph: 281.208.6950
www.staffordfirerescue.org

10210 Mula Road,
Stafford, Texas 77477



HANK MANN



RE/MAX
FINE PROPERTIES
It's time to expect more
MLS



RE/MAX Fine Properties
Broker Associate
RE/MAX Hall of Fame

RESIDENTIAL/COMMERCIAL
SALES/LEASING

Cell: 713-582-1654

Office: 281-265-5533

Email: HMann@remax.net

Proudly serving Fort Bend County for 25 Years

Simpson's Tree Service



- Tree Trimming
- Tree Removal
- Senior Citizen Discount!
- FREE Estimates!

\$50 OFF
All services over \$500
\$25 OFF
All services under \$500
with coupon only

**Proudly Serving the Greater
Houston Area for over 19 Years!**

Insured for your protection..
www.SimpsonsTreeService.com

When Quality Counts...
Call 281.980.0095

LET ME SAVE YOU TIME & MONEY!

*Accurate, efficient and personable
accounting services for a reasonable fee.*

Tax Preparation & Planning
Accounting & Bookkeeping

I specialize in small
to mid-size businesses
including Partnerships,
S-corps and C-corps
as well as individuals,
trusts and gift tax.



TAMARA L. MIHAIL
CPA, LLC
TAX & ACCOUNTING SERVICES

CALL OR EMAIL NOW!
(281) 989-5361
Tammy@MihailCPA.com

12135 Monticeto Lane
Meadows Place, TX 77477
www.MihailCPA.com

Meadows Place Resident

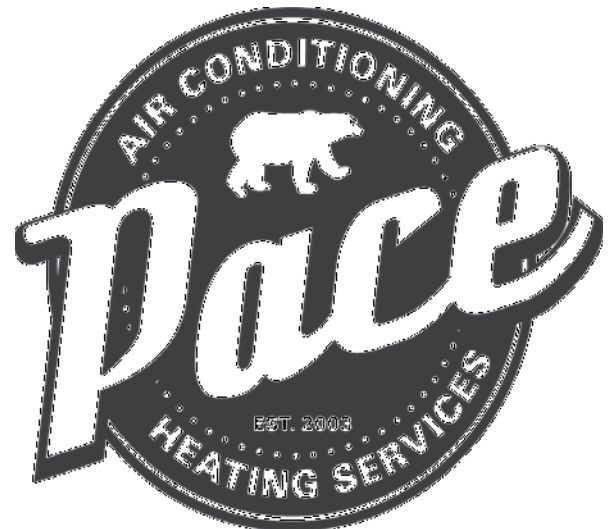

281-208-2665



13335 Murphy Road, Suite B | Stafford, TX 77477
www.pace-ac.com | admin@pace-ac.com

TACLA021694C



Houston

Replacement Windows

Premium White Vinyl * Double Pane * Lifetime Warranty * Professional Installation * Home of the Ultimate Energy Saver * Starting at \$189!!!



Summer Specials

\$\$ Huge Savings \$\$
Call Now and Ask About
FREE Window Upgrades

**FREE
ESTIMATES**

(281) 458-4081

www.WindowCityHouston.com

Level Pro Home Services

FOUNDATION REPAIR Remodel & More!

"A Happy Home Begins with a Solid Foundation"



Windows • Siding • Flooring • Kitchen & Bath

Financing Available & Insurance Claims Welcome

Showroom: 920 Murphy Rd. # C
Stafford, TX 77477
Randy Rose
281-397-2299 / 888-461-4669
cell 832-894-0781
fax 281-969-5190



LEVELPROHOMESERVICE.COM



THE GALAXIE JEWELERS

WE CREATE THE UNUSUAL

Family Owned Since 1972

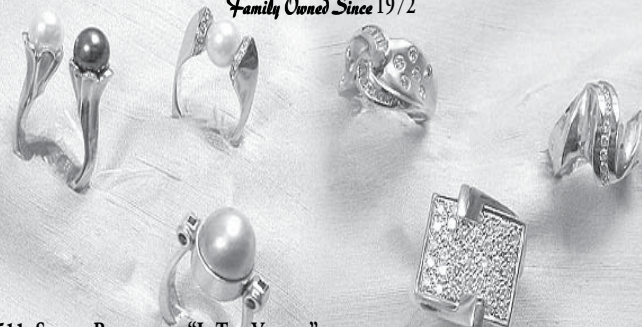

2511 SUNSET BOULEVARD "IN THE VILLAGE"
(713) 521-2511 • FAX (713) 521-3700
www.TheGalaxieJewelers.com

Our Pleasure is to Serve

TruCare Transportation, LLC



*For Your Medical & Transportation Needs ...
We Are Just a Phone Call Away*

Leslie Cumby, Owner

**NON-EMERGENCY
WHEEL CHAIR ACCESSIBLE**

**Tel: 713.771.1554
Fax: 713.771.1559**

TRANSPORT TO:

- † General Medical Appointment
- † Active Living Senior Living Communities
- † Assisted Living Communities
- † Dialysis
- † Nursing Facilities
- † Out-Patient Surgery
- † Patient Discharge
- † Senior Day Care
- † Therapy
- † Rehabilitation

RECREATIONAL AFFAIRS:

- * Special Events
- * Grocery Shopping
- * Church Services
- * Airport Shuttle
- * Hotel Stay
- * Train & Bus Station
- * Funerals
- * Weddings, Etc.

**TruCare
Transportation, LLC**

James O. McDonald

*Certified Public Accountant
Serving Our Clients since 1973*



Jim McDonald CPA



Income Tax Planning & Preparation

- Estimating & Planning
- Individual
- Businesses
- Sales Tax
- Property Tax
- Texas Franchise Tax
- Estate Tax



Accounting & Bookkeeping for Small & Medium Size Businesses

- Business and Personal Financial Statements.
- Monthly Bookkeeping.
- Assist in Selection of Accounting Software.
- Financial Analysis and Planning

"We are committed to providing high quality accounting service at reasonable cost. Allow us to provide your accounting services!"

Jim McDonald

7100 Regency Square Blvd • Suite 220
Houston, TX 77036 • Phone: (713) 771-4628 • Fax: (713) 532-9316

**Bugs bugging you?
BUZZ US!**

Mr. Mike

PEST CONTROL



FREE Home Evaluations & Estimates
Not valid for WDI reports

\$100 OFF
Any Complete Termite Treatment
With coupon.

\$25 OFF

Ant & Flea Service
With coupon.

\$59⁰⁰

Initial Roach Service
With coupon.

\$89⁰⁰

House & Yard Spray
With coupon.

MEADOWS PLACE RESIDENT
Locally Owned and Operated...

- ✓ 25 Years of Experience
- ✓ Termites & General Pests
- ✓ Free Inspections
- ✓ WDI Inspections/Reports
- ✓ Insured

Direct: 281-610-1053
or 281-564-1163

MrMikePC@sbcglobal.net



Offer Ends Soon - Call Today



Let the
**GOOD
TIMES
Roll**

SELL US YOUR CAR!



TEXASDIRECTAUTO.COM

Meadows Place 2014 Real Estate Report

As Reported by MLS

A Total of 46 Houses Sold in Meadows Place
39 in Meadows Sec. Built 1969-1974
7 in Meadowglen Sec. Built 1979-1995

Meadows			Meadowglen		
High	\$180,000	\$91.58 per sq. ft.	High	\$198,000	\$89.74 per sq. ft.
Low	\$104,000	\$56.17 per sq. ft.	Low	\$115,000	\$46.48 per sq. ft.
Median	\$152,000	\$72.72 per sq. ft.	Median	\$159,300	\$77.31 per sq. ft.

Average day on the market: 15 *Average day on the market: 18*

Compared to 2013

A Total of 54 Houses Sold in Meadows Place

Meadows			Meadowglen		
Median	\$141,875	\$69.67 per sq. ft.	Median	\$155,865	\$68.84 per sq. ft.

Average day on the market: 27 *Average day on the market: 34*

*Prices are up & days on the market are down.
It's a great time in Meadows Place Real Estate!*



Anita Milne
Beard Realty Group
(281) 413-9732
milneanita@yahoo.com



Your Neighborhood Realtor for Buying or Selling Your Home



One Troyan Drive • Meadows Place, TX 77477
www.cityofmeadowsplace.org

Prsrt Std
 U.S. Postage
PAID
 Stafford, TX
 Permit No. 36

City of Meadows Place

One Troyan Drive • Meadows Place, TX 77477
 (281) 983-2950 • Fax (281) 983-2940

- Charles D. Jessup, IV**...MAYOR (281) 642-7702
 e-mail: mayor@cityofmeadowsplace.org
 - Terry J. Henley**...MAYOR PRO TEMPORE..... (281) 530-7136
 e-mail: alderman4@cityofmeadowsplace.org
 - John F. Isbell**...ALDERMAN 1 (804) 240-4982
 e-mail: alderman1@cityofmeadowsplace.org
 - Kelle K. Mills**...ALDERMAN 5 (281) 933-0374
 e-mail: alderman5@cityofmeadowsplace.org
 - Steven H. Bezner**...ALDERMAN 2 (281) 401-9339
 e-mail: alderman2@cityofmeadowsplace.org
 - Rick J. Staigle**...ALDERMAN 3 (713) 446-4566
 e-mail: alderman3@cityofmeadowsplace.org
- *****
- Janice M. Moore**...CITY SECRETARY (281) 983-2931
 e-mail: jmoore@cityofmeadowsplace.org

- *****
- EMERGENCY 9-1-1
 - CITY HALL (9:00 a.m. - 4:00 p.m.) Mon-Fri (281) 983-2950
 - POLICE DEPARTMENT / 24 Hours (281) 983-2900
 - FT. BEND COUNTY SHERIFF (281) 342-6116
 - WATER AND SEWER (281) 398-8211
 - FT. BEND COUNTY COURTHOUSE (281) 342-3411
 - ANIMAL CONTROL (281) 342-1512
 - PARKS AND RECREATION DEPARTMENT (281) 983-2935

Community Center Rental

Building Capacity 165
 Rental includes tables and chairs to accommodate events
Food/no alcohol.....\$200.00 Food/with alcohol.....\$300.00
(Cash deposit required equal to Rental Fee)

Community Pool Rental.....\$350.00
(after Community Hours, maximum rental time is 3.5 hours)

Non-Meadows Place residents add \$175.00 to above rates

Resident Community Center/ Pool Combo Rental
Available May - September
Meadows Place residents receive a \$50 discount when renting the Community Center & Pool for the same event.

For rental reservation information, go to cityofmeadowsplace.org click on Parks & Recreation, then Community Center

To check availability, call (281) 983-2935 or email: parks3@cityofmeadowsplace.org or monya@cityofmeadowsplace.org

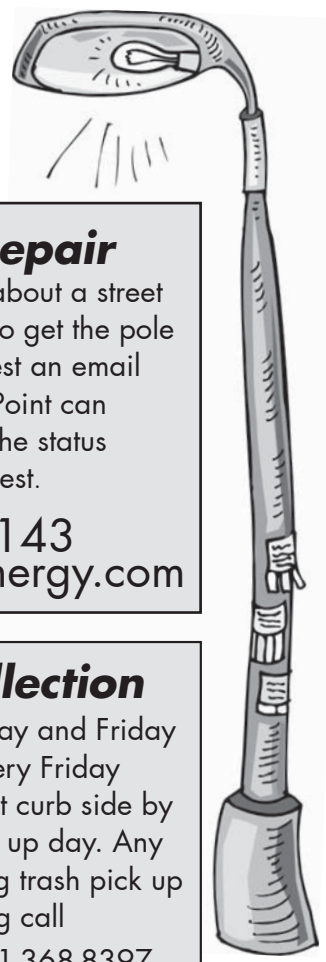

Street Light Repair
 When calling or emailing about a street light outage, you will need to get the pole number. You may request an email notification so Center Point can keep you apprised of the status of the repair request.

1-800-332-7143
www.centerpointenergy.com

WCA Trash Collection
 Trash pick up is every Tuesday and Friday / Recycling every Friday
 Please have trash at curb side by 7:00am each pick up day. Any questions concerning trash pick up or recycling call WCA direct at 281-368-8397.

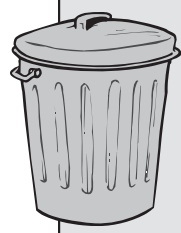

Storm Water Hotline
 Report dumping in storm water drains. Only **RAIN WATER** is allowed
 281-983-2932 or report online, see website.
 For updates on Public Works News visit the website.
publicworks@cityofmeadowsplace.org